

Technical Profile

GSP frames I & II

Magnet drive, end suction, centrifugal pumps to API 685 (2nd edition)

HMD Kontro

The GSP is a heavy-duty centreline-mounted process pump that complies with API 685 and refinery applications for sealless pumps. The GSP product covers a hydraulic range that is split between four frame sizes, Frames I, II, III & IV.

The pumps are offered with a range of Synchronous Magnet Drives rated to match prime mover performance. A corresponding range of Torque Ring drives is available for high temperature operation. Prime mover specifications of all denominations can be catered for.

The standard materials of construction are A8 and S5 with silicon carbide internal bearings.

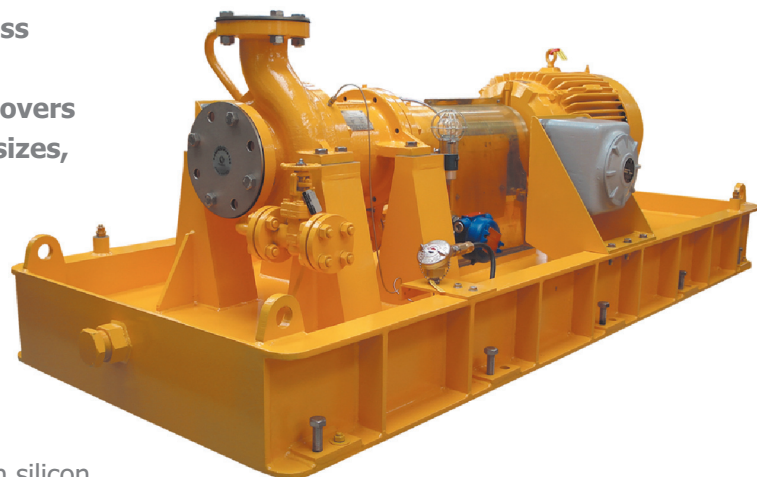

Performance of the GSP frames I & II

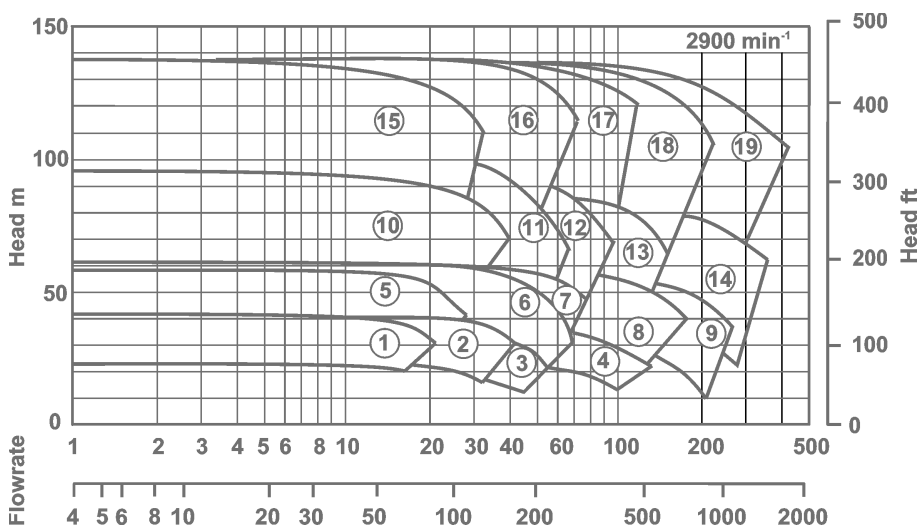

Pump model

1	1.5 x 1 x 6	6	3 x 1.5 x 8H	11	3 x 1.5 x 10	16	3 x 1.5 x 13
2	3 x 1.5 x 6H	7	3 x 2 x 8	12	3 x 2 x 10	17	3 x 2 x 13
3	3 x 2 x 6	8	4 x 3 x 8H	13	4 x 3 x 10H	18	4 x 3 x 13
4	4 x 3 x 6	9	6 x 4 x 8H	14	6 x 4 x 10	19	6 x 4 x 13
5	1.5 x 1 x 8	10	2 x 1 x 10	15	2 x 1 x 13		

Design range limits

The GSP pump is designed to operate from -40°C up to 350°C, -40°F up to 660°F without the need for any ancillary cooling medium. Design working pressure is 40 bar, 580 psi.

Solids handling capability

The unit is capable of handling solids up to 5% w/w less than 150 microns.

Options

Materials of construction

Wetted parts	Alloy 20, Alloy C276
Internal bearings	SiC / Carbon
Gasket	PTFE

Other options

- Casing drains flanged or screwed
- Jacketed pump casing
- Torque ring drive
- Secondary Control
- Coupling housing drain
- Full range of pump protection

Key Design Features

- **No seals:** To minimise maintenance, all of the associated costs and eliminate potential leaks.
- **Sealless design:** For total containment, essential for hazardous, aggressive or valuable product.
- **Interchangeability of components:** For maximum convenience and reduced stock holding, operator training etc.
- **High efficiency wet end:** To benefit maximum flow / head coverage.
- **Wide choice of materials:** To allow a choice of various metals in the construction of your pump.
- **Casing gasket fully confined:** So eliminating risk of blowout.
- **Universal connection options:** So that suction and discharge flange connections can be configured to your exact requirements.
- **Modular rotating element cartridge:** Providing the most efficient way to perform replacements and manage your spare part inventory.

Benefits of GSP pump range

- Conforms to API 685 for sealless pumps.
- Design ensures safe, leak free operation.
- Increased efficiency, low running costs.
- Minimal spares holding and maintenance.
- Maximises on-line process time.
- No costly seal support systems to maintain.
- Reduced installation costs.

Construction of GSP frames I & II

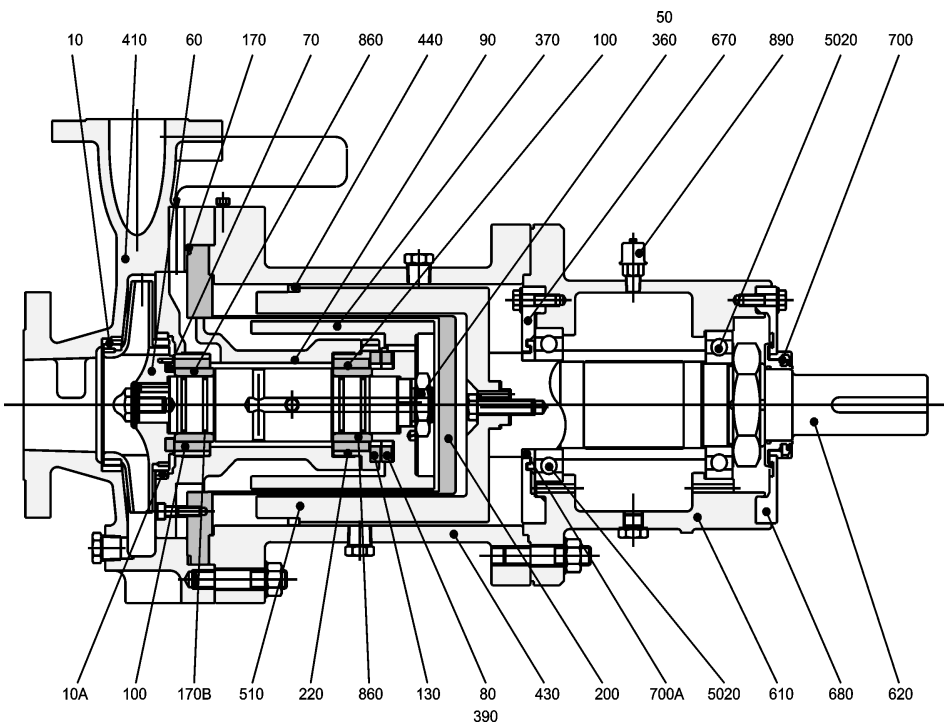

10	Neck Ring [Front]	Stainless Steel
10A	Neck Ring [Back]	Stainless Steel
50	Coupling Washer	Stainless Steel
60	Impeller	Stainless Steel
70	Front Thrust Washer	Alpha SiC
80	Back Thrust Washer	Alpha SiC
90	Bush Holder	Stainless Steel
100	Bush	Alpha SiC
130	Thrust Pad	Alpha SiC
170	Casing Gasket	CSF
170B	'O' Ring	Viton A
200	Containment Shroud	Alloy C & SS
220	Rear Bush Housing	Stainless Steel
360	Coupling Nut	Stainless Steel
370	Inner Magnet Ring	Stainless Steel
390	Support Gasket	Exfoliated Graphite & SS
410	Casing	Stainless Steel
430	Coupling Housing	Carbon Steel
440	Bump Ring	Phosphor Bronze
510	Outer Magnet Ring	Carbon Steel
610	Bearing Housing	Carbon Steel
620	Drive Shaft	Carbon Steel
670	Front Cap	Carbon Steel
680	Back Cap	Carbon Steel
700	Labyrinth Seal [Kit]	Brass
700A	Sec. Containment Seal	Proprietary
860	Shaft Sleeve	Alpha SiC
890	Breather	Stainless Steel
5020	Race	Steel
****	Fixings [Kit]	Various

Flanges and Connections

Casing

Suction and discharge flanges are designed in accordance with the following relevant standards:

ANSI B16.5 Class 300 Machined with 1.5mm (0.06") high raised face having a continuous spiral groove.

DIN 2545 PN40 Machined with 2mm high raised face with a continuous spiral groove. (Note: these flanges are identical to BS 4504 PN40).

Flange Loadings

Allowable flange loadings imposed by pipework are in accordance with Table 4 of API 685 2nd edition.

Drain Connections

The following drain options are available:

Standard: Socket welded flanged drain rated to the casing flanges, fully braced in 2 planes.

Option 1: $\frac{3}{8}$ " BSP drain plug fitted with fully trapped gasket.

Option 2: $\frac{1}{2}$ " NPT plug.

Option 3: No drain.

Gauge Connections:

Suction and discharge flanges are fitted with bosses suitable for drilling.

Dimensions of GSP frames I & II

Dimensions are for guidance only

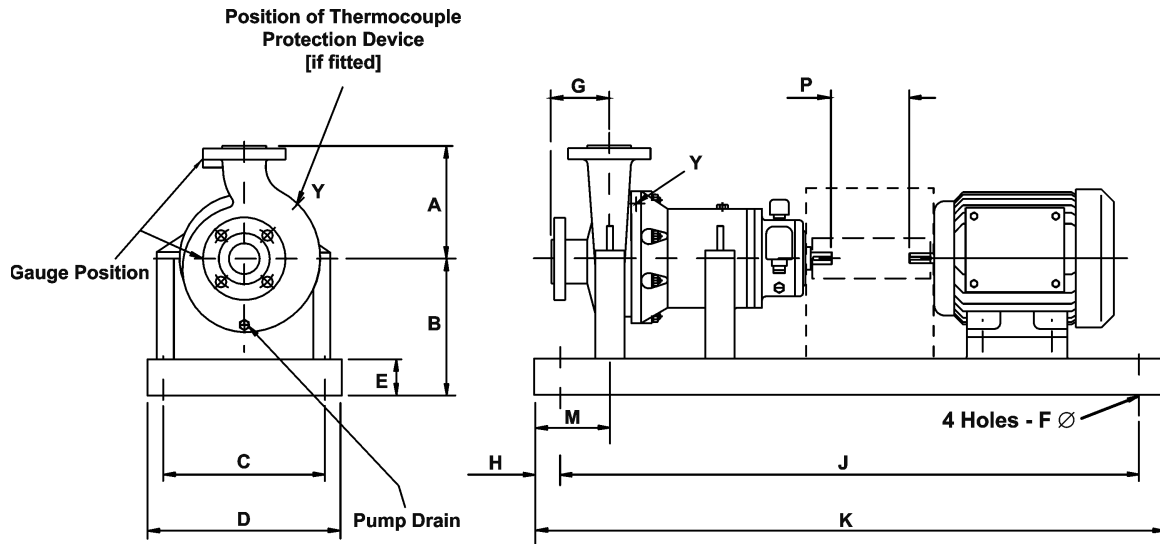

Pump size	A	G	M	B1	Pump size	A	G	M	B1	Pump size	A	G	M	B1
1.5x1x6	190/7.5"	102/4"	119.4/4.5"	5.25	3x2x8	241/9.5"	102/4"	119.4/4.5"	8.25	4x3x10H	300/11.8"	102/4"	119.4/4.5"	8.25
3x1.5x6H	190/7.5"	102/4"	119.4/4.5"	5.25	4x3x8H	300/11.8"	102/4"	119.4/4.5"	8.25	6x4x10	343/13.5"	102/4"	119.4/4.5"	10
3x2x6	190/7.5"	102/4"	119.4/4.5"	5.25	6x4x8H	280/11"	102/4"	119.4/4.5"	8.25	2x1x13	266/10.5"	102/4"	119.4/4.5"	10
1.5x1x8	200/7.87"	102/4"	119.4/4.5"	5.25	2x1x10	228/9"	102/4"	119.4/4.5"	8.25	3x1.5x13	275/10.8"	102/4"	119.4/4.5"	10
3x1.5x8H	200/7.87"	102/4"	119.4/4.5"	5.25	3x1.5x10	228/9"	102/4"	119.4/4.5"	8.25	3x2x13	292/11.5"	102/4"	119.4/4.5"	10
4x3x6	228/9"	102/4"	119.4/4.5"	8.25	3x2x10	241/9.5"	102/4"	119.4/4.5"	8.25	4x3x13	320/13"	102/4"	119.4/4.5"	10

GSP Frames I & II

Dimension P= 25.4/1" for non spacer type and 100/4" for spacer type.

Motor Frame	B(B1=5.25)	B(B1=8.25)	B(B1=10)	C	D	E	F	H	J	K
90-100-112	229/9"	311/12.25"	356/14"	229/9"	305/12"	90/3.5"	19/0.75"	32/1.25"	927/36.5"	990/39"
132	229/9"	311/12.25"	356/14"	229/9"	305/12"	90/3.5"	19/0.75"	32/1.25"	927/36.5"	990/39"
160-180	281/11"	311/12.25"	356/14"	305/12"	381/15"	102/4"	19/0.75"	32/1.25"	1257/49.5"	1321/52"
200	311/12.25"	356/14"	381/15"	381/15"	457/18"	102/4"	25/1"	32/1.25"	1472/58"	1535/60.5"
225	311/12.25"	356/14"	381/15"	381/15"	457/18"	102/4"	25/1"	32/1.25"	1490/59"	1560/61.5"
250	311/12.25"	381/15"	381/15"	533/21"	609/24"	102/4"	25/1"	32/1.25"	1638/64.5"	1700/67"
143-145	229/9"	311/12.25"	356/14"	229/9"	305/12"	90/3.5"	19/0.75"	32/1.25"	927/36.5"	990/39"
182-184	229/9"	311/12.25"	356/14"	229/9"	305/12"	90/3.5"	19/0.75"	32/1.25"	927/36.5"	990/39"
213-215	229/9"	311/12.25"	356/14"	229/9"	305/12"	90/3.5"	19/0.75"	32/1.25"	927/36.5"	990/39"
254-256	281/11"	311/12.25"	356/14"	305/12"	381/15"	102/4"	19/0.75"	32/1.25"	1257/49.5"	1321/52"
284-286	311/12.25"	356/14"	381/15"	381/15"	457/18"	102/4"	25/1"	32/1.25"	1472/58"	1535/60.5"
324-326	311/12.25"	356/14"	381/15"	381/15"	457/18"	102/4"	25/1"	32/1.25"	1490/59"	1560/61.5"
364-365	311/12.25"	381/15"	381/15"	533/21"	609/24"	102/4"	25/1"	32/1.25"	1638/64.5"	1700/67"

Range capabilities

Model	Head	Flow	Design Temperature	Design Pressure	Viscosity cSt	Mounting
GSP I	60 m 196 ft	52 m ³ /h 229 USgpm	-40 to 350°C -40 to 660°F	40 bar 580 psi	200	Separate Mounted (SM)
GSP II	138 m 452 ft	405 m ³ /h 1784 USgpm	-40 to 350°C -40 to 660°F	40 bar 580 psi	200	Separate Mounted (SM)

Pressure Limits

All parts are to be rated to the pressures shown below at 38°C / 100°F

Flange standard	Design pressure		
	A8/S5	Alloy 20	Alloy C
ANSI B16.5 Class 300	4.0 MPa 580 psi	3.4 MPa 490 psi	2.0 MPa 290 psi
Component	Hydrostatic test value		
	A8S/5	Alloy 20	Alloy C
Casing (ANSI 300lb)	6.0 MPa 870 psi	5.1 MPa 735 psi	3.1 MPa 450 psi
Containment Shroud/Shell			

Tested in accordance with the relevant casing

Temperature limits

	Synchronus Coupling	Torque Ring Coupling
Standard Range	-40°C to 205°C (-40°F to +400°F)	-40°C to 350°C (-40°F to 660°F)
Option	-40°C to 260°C (-40°F to +500°F)	-40°C to 400°C (-40°F to 750°F)

Sundyne Headquarters:

Sundyne, LLC

14845 West 64th Avenue
Arvada, Colorado 80007
USA
1-866-Sundyne
Phone: 1 303 425 0800
Fax: 1 303 940 2911
www.sundyne.com

Sundyne United Kingdom:

Sundyne HMD Kontro Sealless Pumps

Marshall Road
Hampden Park Industrial Estate
Eastbourne, East Sussex, BN22 9AN
United Kingdom
Phone: +44 (0)1323 452000
Fax: +44 (0)1323 503369

Sundyne China:

Sundyne Industrial Equipment (Tianjin) Company Limited

Building 1, No. 879 Shen Fu Road
XinZhuang Industrial Zone
Min Hang District
Shanghai, China 201108
Phone: +86 21 5055 5005
Fax: +86 21 5442 5265

Sundyne France:

Sundyne International S.A.

13-15, Bld. Eiffel - B.P. 30
21604 Longvic Cedex
France
Phone: +33 (0)3 80 38 33 00
Fax: +33 (0)3 80 38 33 66

Sundyne Spain:

Sundyne Marelli Bombas, S.R.L.

Ctra. Madrid-Toledo, Km.30.8
45200 Illescas
Toledo, Spain
Phone: +34 925 53 45 00
Fax: +34 925 51 16 00

Worldwide Sales Headquarters

Unit 2 Harvington Business Park
Brampton Road
Hampden Park Industrial Estate
Eastbourne East Sussex, BN22 9BN
United Kingdom
Phone: +44 (0)1323 452125

All information provided is subject to change without notice.

© 2014 Sundyne, LLC
All Rights Reserved. Other logos and trade names are property of their respective owners.

Sundyne HMD Kontro
GSP 2.0 8/14 A4 Eng.